

ZAP-800Ex-B Explosion-proof Zero Air Purifier

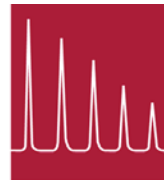

Explosion-proof Zero Air Purifier

ZAP-800Ex-B explosion-proof zero air purifier (hereinafter referred to as explosion-proof zero air purifier) can be used for combustion air of FID detectors, purge gas of Fourier spectrometers, zero gas and reference gas of analyzers without carbon hydrocarbons. The content of THC in the purified zero point air is less than 10 ppb.

Specifications

- Max flow: 1.5 slpm
- Inlet pressure: 300~800 KPag
- Maximum pressure drop (inlet pressure: 800 KPag, flow rate: 1.5 slpm) : < 30KPag
- Air inlet/outlet interface: 1/8 "sleeve connector (other interface specifications are optional)
- Inlet air temperature: 0-35 °C
- Inlet air dew point temperature: < the ambient temperature 5°C;
- Outlet air temperature: < 50°C
- Inlet air THC content: <100 ppm
- THC content in outlet air: < 10 ppb
- Operating temperature: 350~400°C
- Preheating time: about 30min
- Ambient temperature: -5 ~ +50 °C
- Storage temperature: -20 ~ +65 °C
- Relative humidity: < 95%
- Installation location: indoor installation
- Voltage: 220 VAC, -10 /+ 10%, 48-62 Hz
- Power: 45W
- Explosion-proof class: Ex db IIB+H2 T4 Gb
- Certificate No.: DTI 20ATEX0507X
- Purifier shell: cast aluminum
- Material of the part in contact with the medium: 316SS
- Weight: about 6Kg
- Dimensions of explosion-proof zero air purifier: see FIG. 1.:

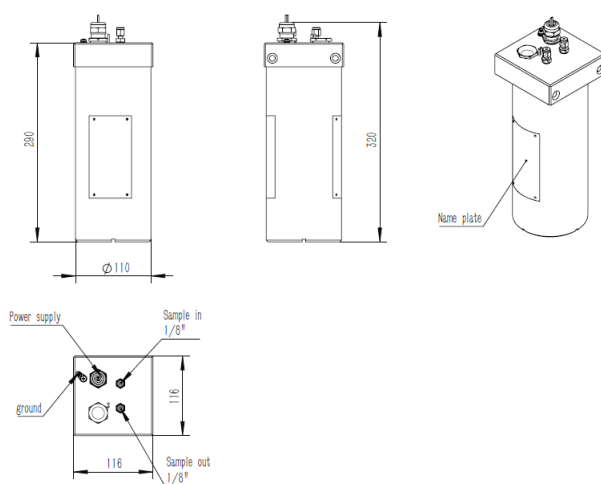

Figure 1 Purifier mounting dimensions

To discuss which part may be suitable for your application or for further information please contact: